

Maintenance Advice for Educators

SOUNDFIELD TECHNOLOGY CHECKLIST & MAINTENANCE GUIDE

ASSESS WHICH REDCAT SOUNDFIELD SYSTEM YOUR SCHOOL IS USING

These Redcat Soundfield systems ARE SUPPORTED

Identify your Redcat by its model logo above the screen to assess the compatible microphones.

LOOK FOR THIS LOGO

Redcat
POINT-TO-PAIR-)



Redcat (RCN)
Post 2022

Flexmike Sharemike
THESE MIKES ONLY WORK WITH THIS MODEL REDCAT

LOOK FOR THIS LOGO

Redcat Access™



Redcat Access (RCA)
Pre 2022

Flexmike Sharemike
THESE MIKES ONLY WORK WITH THIS MODEL REDCAT

ALL SPARES ARE AVAILABLE FOR THESE SYSTEMS.

These Redcat Soundfield systems are NOT SUPPORTED and are DISCONTINUED

WHITE REDCAT IR



Redcat IR

THIS MIKE ONLY WORKS WITH THIS MODEL REDCAT

BLACK REDCAT IR



Redmike IR

Redcat (RC2)

THIS MIKE ONLY WORKS WITH THIS MODEL REDCAT



Redmike IR
(DISCONTINUED)

Only battery (NH2A27) available

Please note that a Redmike is only compatible with a white Redcat or black IR Redcat shown. IT IS NOT COMPATIBLE WITH REDCAT ACCESS OR REDCAT POINT TO PAIR SHOWN ABOVE.

ALL SPARES FOR WHITE & BLACK REDCATS IR ARE DISCONTINUED

Maintenance Advice for Educators

INSTALLATION AND TROUBLESHOOT A BLACK REDCAT ACCESS

Redcat Access™

The Redcat Access speaker / amplifier with power supply, needs to be located, together with the Flexmike and Sharemike.



HOW TO POWER UP REDCAT ACCESS:

Make sure the Redcat Access is connected properly to power. Obviously, this means the power cable is plugged fully into a functioning power point, the power cable is firmly pressed into the black brick transformer, and connected to the Redcat properly.

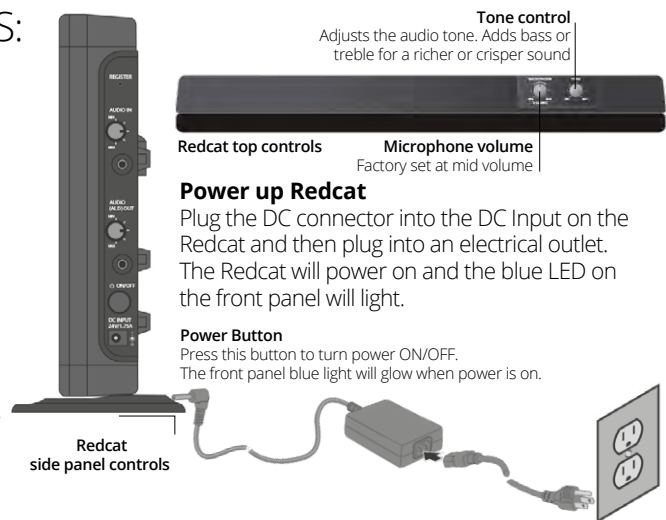

HOW TO ASSESS THE MIKES:

It is highly likely existing batteries inside Flexmikes and Sharemikes are out of warranty and/or worn out. Batteries can be sourced here. hearandlearn.com.au/products There will need to be batteries in the Flexmikes or Sharemikes to work. The batteries shown are the **ONLY** ones that can be used in Sharemikes and Flexmikes.



REPLACING BATTERIES IN FLEXMIKES (Battery part #NH.4V)

1. Slide the battery door open.
2. Carefully pull the battery away from the Flexmike and disconnect the cable.
3. Connect the cable of the new battery pack as shown and insert the battery pack into the compartment.
4. Slide the cover back on and snap into place.
5. Place the Flexmike into the cradle charger to charge the battery pack.

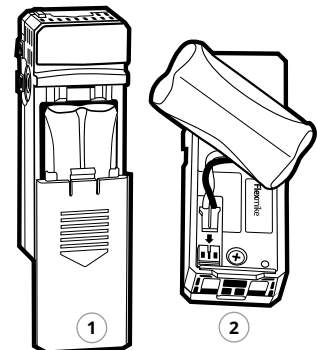

Maintenance Advice for Educators

INSTALLATION AND TROUBLESHOOTING FOR ACCESS FLEXMIKE AND SHAREMIKE

Redcat Access™



CHARGING THE FLEXMIKE

Before use, the Flexmike should be charged. It will take **5-6 hours** for the Flexmike to obtain a full charge. A fully charged Flexmike will last for up to **8 hours** of use.

If microphones are used daily, they **must** be charged overnight.

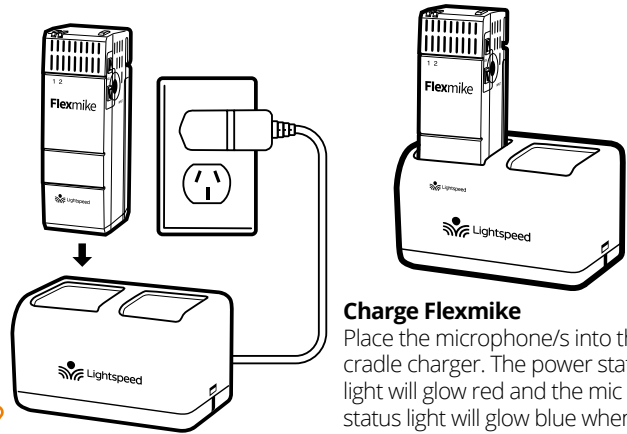

Connect cradle charger
Plug power cord into the cradle charger and then plug into a power point.

Charge Flexmike

Place the microphone/s into the cradle charger. The power status light will glow red and the mic status light will glow blue when it is charging. When charging is complete, the power status light will glow green. It takes about 5-6 hours to fully charge the microphone battery.

DAILY USE OF THE FLEXMIKE

Remove the Flexmike from the charger and put it on by connecting the magnetic clasps behind your neck. Adjust the lanyard so that the top of the Flexmike aligns with the collarbone.

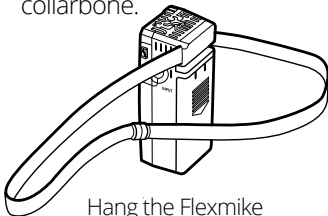

Hang the Flexmike on the lanyard opposite the magnetic clasp.



Align with collarbone

While speaking in a normal voice, fine tune the microphone volume. Proper volume level should be as follows:

- Your voice should be clearly heard by another person on the other side of the room.
- You should barely be able to hear your own voice.
- There should not be any 'feedback' or squealing outside of 60-90cm, if there is turn the volume down slightly.

- 1 The Power/Mute button**
Press and hold to power on or off. Press to mute.
- 2 Flexmike volume control**
Microphone volume may be adjusted at the microphone by using the UP/DOWN buttons on the side of the Flexmike.

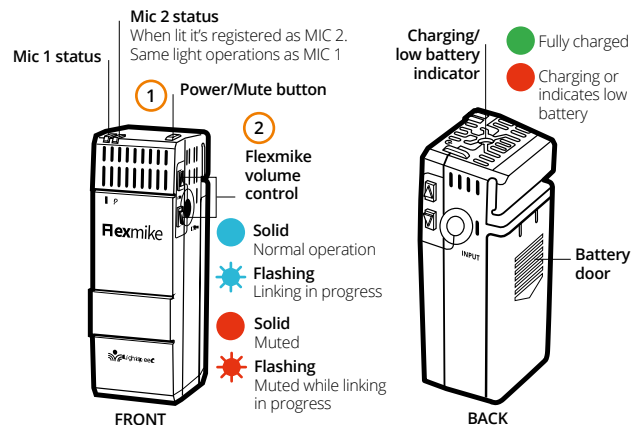

REMEMBER:

This equipment supplements the user's voice so they are able to speak in a conversational tone. Having the volume set too high will result in feedback and listener fatigue.

- Once initial volume level is set, walk around the room and listen for overall audio quality.
- If further fine tuning is required, you may need to adjust the Tone control on the side of the RedCat.

Maintenance Advice for Educators

INSTALLATION AND TROUBLESHOOTING FOR ACCESS FLEXMIKE AND SHAREMIKE

Redcat Access™



Connect cradle charger
Plug power cord into the cradle charger and then plug into a power point.

CHARGING THE SHAREMIKE

Before use, the Sharemike should be charged. It will take **5-6 hours** for the Sharemike to obtain a full charge. A fully charged Sharemike will last for up to **8 hours** of use.

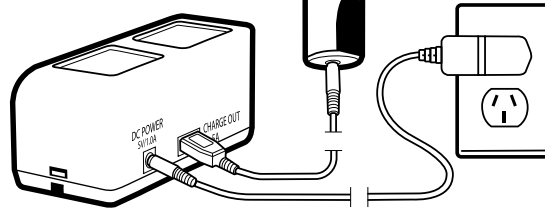

Charge Sharemike

Connect one end of the charging cable into the socket labeled CHARGE on the bottom of the Sharemike. Plug the other end into the USB socket on the back of the cradle charger. Leave the Sharemike plugged in overnight (5-6 hours) to obtain a full charge. The light will turn green when charging is complete.

If microphones are used daily, they **must** be charged overnight.

REPLACING BATTERIES IN SHAREMIKE (Battery part #NH2APK)

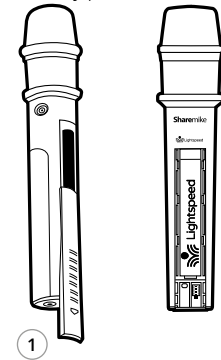

- Slide the battery door open.
- Carefully remove the battery pack from the Sharemike.
- Insert the new battery pack into the compartment, ensuring proper polarity is observed.
- Slide the cover back on and snap into place.
- Connect the Sharemike to a charging cable and plug into the back of the cradle charger to charge the battery pack.

DAILY USE OF THE SHAREMIKE

At the start of the day, remove the Sharemike from the USB lead plugged into charging cradle. Ensure the 955 Access is on. The blue light on the front of the 955 Access will glow.

Turn on the Sharemike by pressing and holding the power button until the LED lights.

Grip the Sharemike in the center section.

While speaking in a normal voice, increase the volume on the 955 Access Microphone volume control knob until your voice is barely audible.

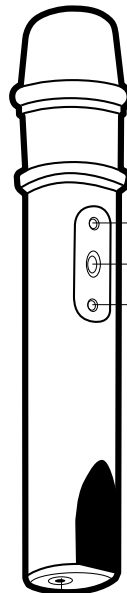

Mic 1 light
Indicates battery/charging status when Sharemike is registered as MIC 2

- Flashing Low battery
- Solid Charging
- Solid Complete charge

Power button

Mic 2 light
Indicates operation status when Sharemike is MIC 1 (Standard)

- Solid Normal operation
- Flashing Linking in process
- Solid Muted

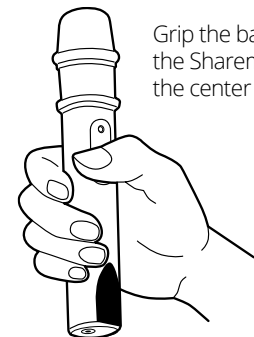
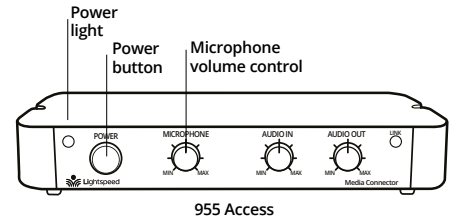

REMEMBER:

This equipment is designed to supplement and distribute the user's voice so they are able to speak in a conversational tone. Having the volume set too high will result in feedback and listener fatigue.

Maintenance Advice for Educators

INSTALLATION AND TROUBLESHOOTING FOR ACCESS FLEXMIKE AND SHAREMIKE

Redcat Access™



Sometimes Flexmikes get mixed up, batteries die or parts go missing. Here are some scenarios you may encounter.

 **ENSURE THE FLEXMIKE IS TURNED ON.**

It may already be on and asleep – push the ON/OFF button quickly to wake it up. It may be completely turned off – push and hold the ON/OFF button for 3 seconds. No lights at all? Probably no charge left. Put the Flexmike in the charging cradle to charge it up.

 **NO RED LIGHT ON THE FLEXMIKE?**

Chances are there is a fault with the charging cradle, or you have put the Flexmike in the cradle the wrong way around. Check its positioning and replace.

 **RED LIGHT AND SOLID BLUE LIGHT(S)?**

Great. Now you're ready to test. Let's make sure everything is running really well! Take out the Flexmike and press the ON/OFF button on the top to wake it up.



 **RED LIGHT AND FLASHING BLUE LIGHTS?**

Each Redcat Access supplied comes with a Flexmike already paired (or 'married') to it. If a Flexmike is taken from the room where the Redcat Access it's 'married' to, it will indicate that it is not paired and is 'looking' for its 'spouse'. You will need to walk from room to room to discover it's Redcat 'spouse'. As a workaround, you can 'marry' or pair a Flexmike with a different Redcat Access. To find out click on the picture below or scan the QR code to view the video.



POSITIONING YOUR REDCAT

You may be restricted in your choices of where to place your Redcat in the classroom. As a rule, in the middle of the longest wall is ideal and if possible avoiding the teaching wall.

Redcat should be placed within 2 metres of an electrical outlet and about 1.5 metres off the ground.

Find a location as far away as possible from the teacher using the microphone. Avoid placing Redcat on any wall close to where the teacher usually stands when instructing the class. If the teacher's microphone is too close to Redcat it may result in annoying feedback.

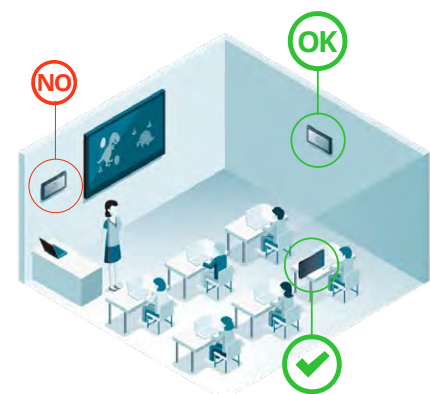

Maintenance Advice for Educators

INSTALLATION AND TROUBLESHOOTING FOR A REDCAT POINT TO PAIR

Redcat

POINT-TO-PAIR-))

The Redcat Point to Pair speaker / amplifier with power supply, needs to be located, together with the Flexmike and Sharemike.



Flexmike (Post 2022) Sharemike (Post 2022)

THE FLEXMIKE AND THE SHAREMIKE ABOVE ARE ONLY COMPATIBLE WITH REDCAT POINT TO PAIR.

HOW TO POWER UP REDCAT POINT TO PAIR:

Make sure the Redcat Point To Pair is connected properly to power. Obviously, this means the power cable is plugged fully into a functioning power point, the power cable is firmly pressed into the transformer, and connected to the Redcat properly.

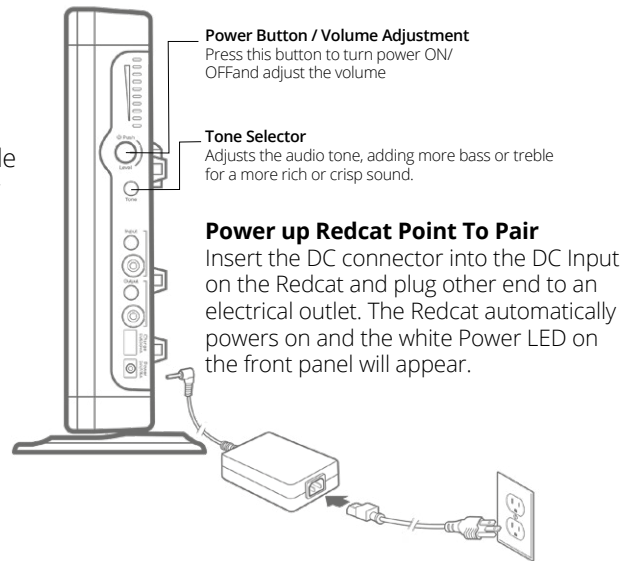

HOW TO ASSESS THE MIKES:

Both Flexmikes and Sharemikes that come with Point To Pair technology share the same lithium polymer battery packs (#L3.7V). Replacement batteries can be sourced here. hearandlearn.com.au/products. There will need to be a battery in the Flexmikes or Sharemikes to work.



REPLACING BATTERIES IN FLEXMIKE & SHAREMIKE (Battery part #L3.7V)

- FLEXMIKE
1. Push down on the latch and carefully pull the battery pack away from the Flexmike.
 2. Insert new battery pack as shown and make sure the latch is secure.
 3. Place the Flexmike in a cradle charger to charge the battery pack.

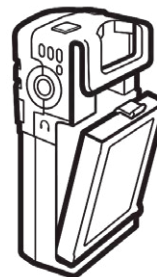

- SHAREMIKE
1. Push down on the latch and carefully pull the battery pack away from the Sharemike.
 2. Insert new battery pack as shown and make sure the latch is secure.
 3. Place the Flexmike in a cradle charger to charge the battery pack.

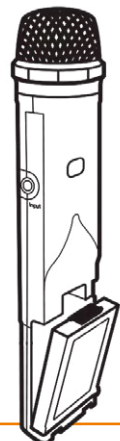

Maintenance Advice for Educators

INSTALLATION AND TROUBLESHOOTING FOR POINT TO PAIR FLEXMIKE AND SHAREMIKE

Redcat POINT-TO-PAIR-3)



Connect cradle charger

Plug power cord into the cradle charger and then plug into a power point.

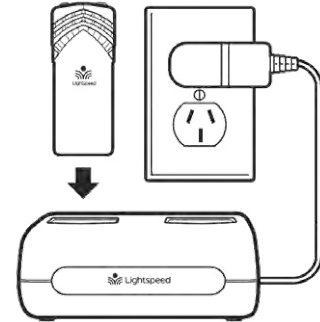

CHARGING THE FLEXMIKE

Before use, the Flexmike should be charged. It will take **5-6 hours** for the Flexmike to obtain a full charge. A fully charged Flexmike will last for up to **8 hours** of use.

If microphones are used daily, they **must** be charged overnight.

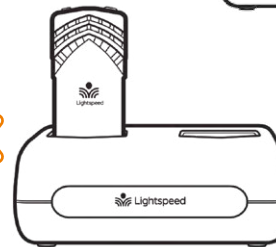

Charging the Flexmike

Place the microphone/s into the cradle charger. The power status light will glow red when it is charging. When charging is complete, the power status light will glow green.

DAILY USE OF THE FLEXMIKE

Remove the Flexmike from the charger and put it on by connecting the magnetic clasps behind your neck. Adjust the lanyard so that the top of the Flexmike aligns with the collarbone.

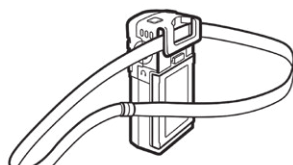

Hang the Flexmike on the lanyard opposite the magnetic clasp.



Align with collarbone

While speaking in a normal voice, fine tune the microphone volume. Proper volume level should be as follows:

- Your voice should be clearly heard by another person on the other side of the room.
- You should barely be able to hear your own voice.
- There should not be any audio "feedback" or squealing outside of 60-90cm (if so, turn the volume down).

To turn off Flexmike, press and hold the power button. To turn back on, press and hold until the power status light turns white.

Private conversations

To mute the Flexmike during private conversations momentarily press the power button. When muted, the blue light turns white. To unmute the Flexmike momentarily press the power button again.

At the end of the day

Place the Flexmike into the cradle charger and make sure the power supply is plugged in to an electrical outlet. The Flexmike will stay powered on during charging, but will automatically be muted.

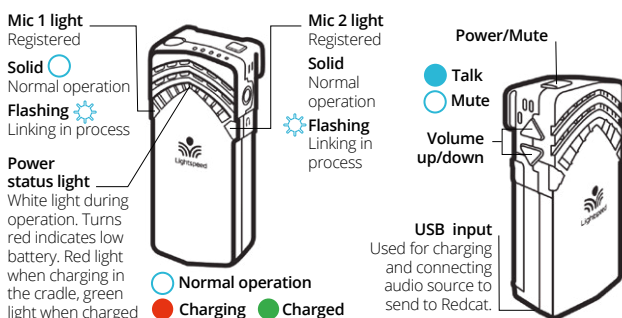

REMEMBER:
Speak in a conversational tone. Having the volume set too high will result in feedback and listener fatigue.
Once the volume level is set, walk around the room and listen for overall audio quality. If further fine tuning is required, you may need to adjust the Tone control on the side of the Redcat (See page 6).

Maintenance Advice for Educators

INSTALLATION AND TROUBLESHOOTING FOR POINT TO PAIR FLEXMIKE AND SHAREMIKE

Redcat POINT-TO-PAIR-3)



Connect cradle charger

Plug power cord into the cradle charger and then plug into a power point.

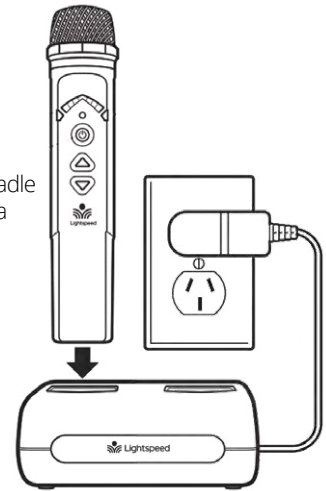

CHARGING THE SHAREMIKE

Before use, the Sharemike should be charged. It will take **5-6 hours** for the Sharemike to obtain a full charge. A fully charged Sharemike will last for up to **8 hours** of use.

If microphones are used daily, they **must** be charged overnight.



Charge Sharemike

Place microphone/s into the cradle charger. The power status light will glow red when it is charging. When charging is complete, the power status light will glow green. Sharemike and Flexmike can be charged together.

DAILY USE OF THE SHAREMIKE

At the start of the day, remove the Sharemike from the cradle charger. Ensure the 975 is on. The white power light on the front of the 975 will glow.

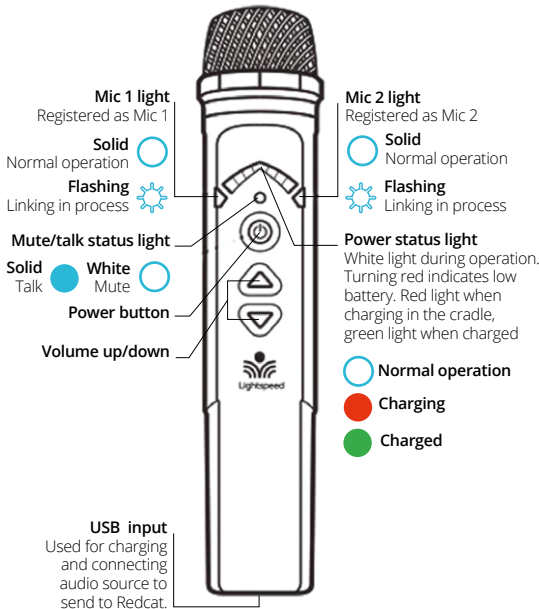
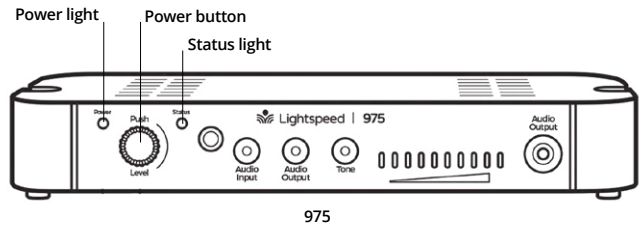

Grip the barrel of the Sharemike in the center section.

Turn on the Sharemike by pressing and holding the power button until the LED lights.

Grip the Sharemike barrel in the center section.

While speaking in a normal voice, increase the volume with the Sharemike until your voice is barely audible.

REMEMBER:

This equipment is designed to supplement and distribute the user's voice so they are able to speak in a conversational tone. Having the volume set too high will result in feedback and listener fatigue.

Maintenance Advice for Educators

INSTALLATION AND TROUBLESHOOTING FOR POINT TO PAIR FLEXMIKE AND SHAREMIKE

Redcat

POINT-TO-PAIR-3)



Pairing your Flexmike or Sharemike microphone To 975, Redcat Or Topcat

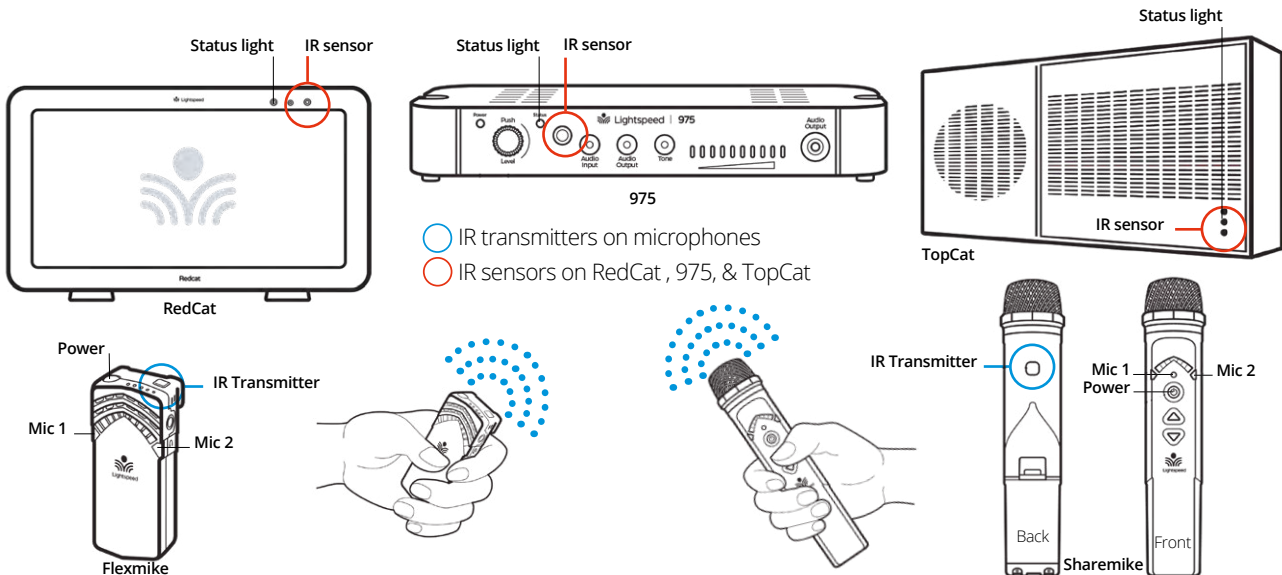

From a powered off state, point the IR transmitter lens toward the IR sensor (marked with red rings on illustrations below) on the 975, RedCat or TopCat (for Sharemike, the transmitter lens is located on the back of the microphone).

Your complete system is shipped pre-paired for quick and easy use. For any reason, you need to pair new components, please refer to the step-by-step video below..

Press and hold the power button for 5 seconds until the Mic 1 and Mic 2 lights start flashing, then release the button and let the pairing process finish.

The "status" light on 975, RedCat and TopCat will light up indicating the pairing process is complete.

The Mic 1 or Mic 2 light on the microphone will stay illuminated.

PAIRING THREE MICROPHONES HELP VIDEO

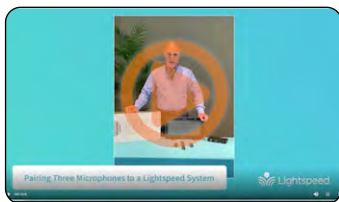

Click on the image or scan the QR code to watch the help video

hearandlearn.com.au/wp-content/uploads/2022/05/Pairing-Three-Microphones-to-a-Lightspeed-System-1.mp4

NEED FURTHER HELP?...

For further information or help email us at info@hearandlearn.com.au or scan the QR code. Leave your mobile number and we will call you back to walk and talk you through your particular issue.

Thanks!
Hear and Learn Help Team

